

M16 x 2.0 THREAD x 1.25 DEEP
C'BORE DIA .670 x .320 DEEP

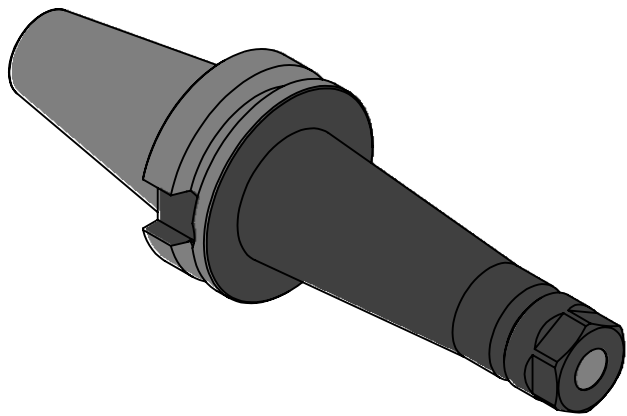
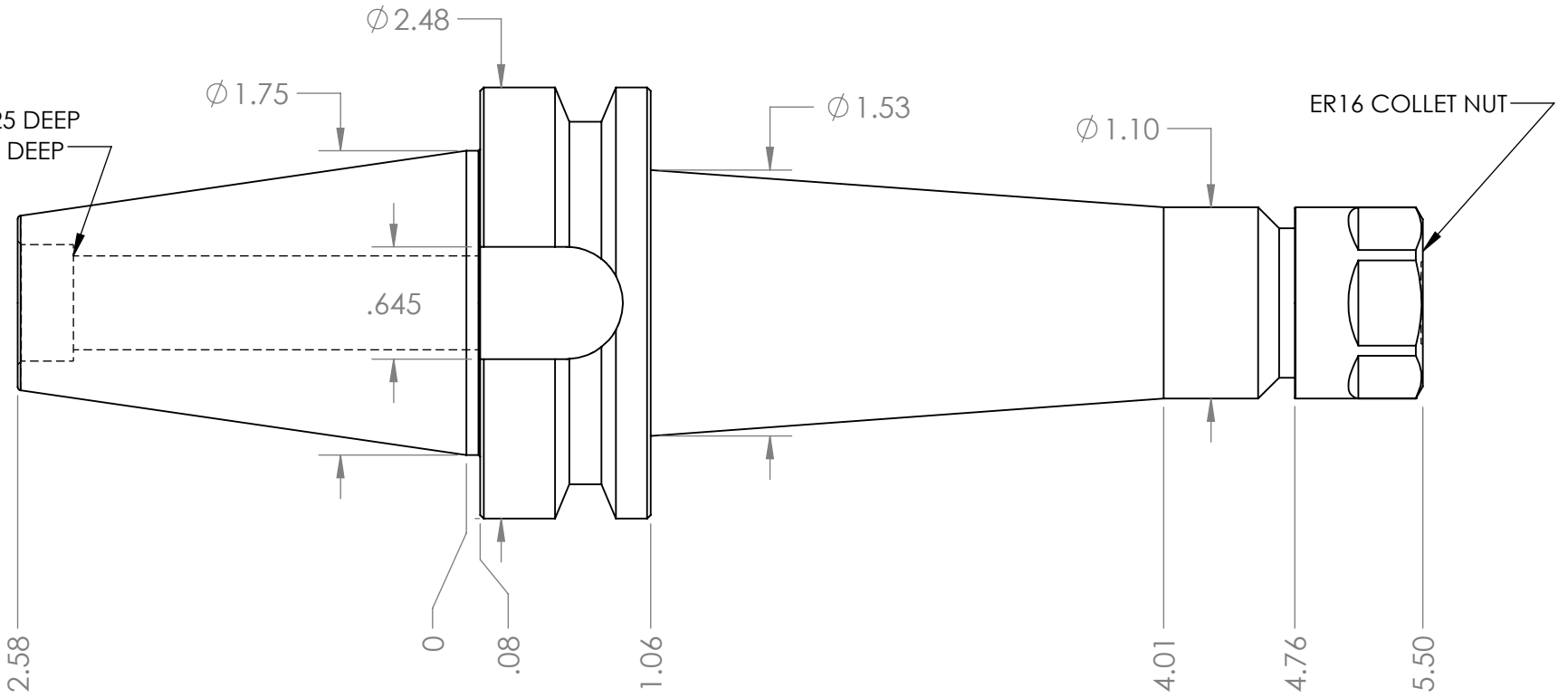

NOTES:

WORKS ON ALL BT40 MACHINES
ACCEPTS ALL ER16 COLLETS FROM .039"-.4375"
USES WRENCH PART # ER16-WRENCH (NOT INCLUDED)
FOR MORE PRODUCT DETAILS PLEASE GO TO MARITOO.COM
AND SEARCH ITEM # LISTED ON THIS PRINT

MARITOO

WWW.MARITOO.COM

ITEM# **BT40 ER16-140T**

Made in USA